

## 6" HOLLOW TYPE

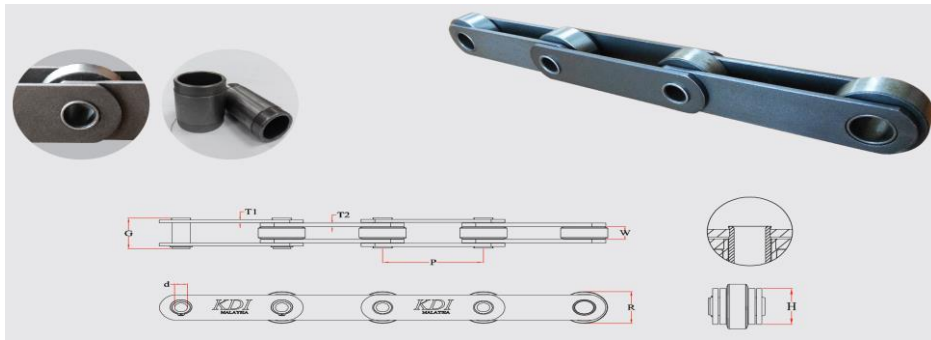

Chain No.	Pitch P	Roller R	Pin D	Inner width W	Total width G	Plate			Maximum Load Lbs	Weight kg/f
						Height H	Thickness T1 T2			
KD64H	152.4	47.6	19.0	19.0	45.0	38.1	4.5	5.5	28,000	1.8
KD66H-WR	152.4	66.7	20.1	25.4	57.0	52.8	6.0	6.0	45,000	3.1
KD66H-EX-WR	152.4	66.7	20.1	25.4	61.0	52.8	6.0	8.0	58,100	3.3
KD68H-WR	152.4	88.9	23.1	38.1	78.0	61.0	8.0	8.0	65,000	6.3

\*mm

## 6" HOLLOW PREMIER TYPE (Larger and Thicker Bush - Design for Fruit Elevator)

### Design For Fruit Elevator

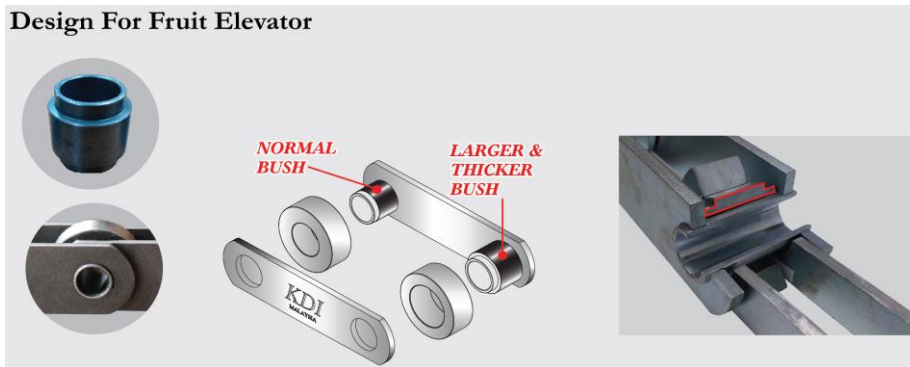

Chain No.	Pitch P	Roller R	Pin D	Inner width W	Total width G	Plate			Maximum Load Lbs	Weight kg/f
						Height H	Thickness T1 T2			
KDP66H-WR	152.4	66.7	20.1	25.4	57.0	52.8	6.0	6.0	45,000	3.1
KD66PH-EX-WR	152.4	66.7	20.1	25.4	61.0	52.8	6.0	8.0	58,100	3.3

\*mm

## 6" HOLLOW TYPE ( Design for Wet Condition)

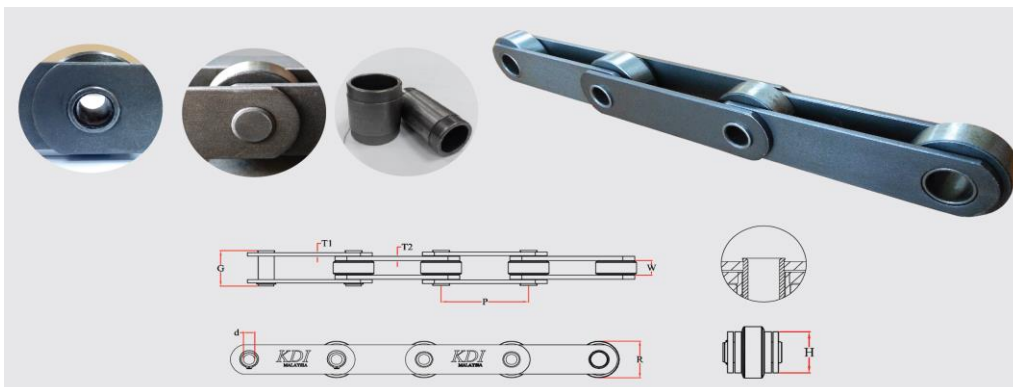

Chain No.	Pitch P	Roller R	Pin D	Inner width W	Total width G	Plate			Maximum Load Lbs	Weight kg/f
						Height H	Thickness T1 T2			
KD66H-PBSS-WR	152.4	66.7	20.1	25.4	57.0	52.8	6.0	6.0	45,000	3.1

\*mm